



EDITORIAL BOARD

Editor in Chief:

Dr. AVLN Sujith
Asst. Professor,
HOD, Dept. of CSE
Editors:

Mrs. A Sandhya Rani,
Asst. Professor,
Dept. of CSE
Mr. V Narahari,
Asst. Professor,
Dept. of CSE
Mr. M Parthasaradhi,
Asst. Professor,
Dept. of CSE

Student Members :

BRG Vamsi Krishna

V CSE

R Jaswanth Reddy

III CSE

Inside this issue:

Vision & Mission, PEO's	1
PSO's & PO's	2
Chat GPT and its Capabilities	3
The Technology behind Face Unlocking in Smartphones	5
Virtual Reality	7
Semantic Web	9
Software Defined Radio	11
Brain controlled car for disabled using Artificial Intelligence	13
The Role of Artificial Intelligence in Healthcare Industry	17
Face Identification and Recognition	19

DIGIT



Department of Computer Science & Engineering
Anantha Lakshmi Institute of Technology & Sciences

Volume 09

Jan - Jun 2023

VISSION & MISSION

VISION : To produce technically competent computer science professionals with high quality education in cutting edge technologies and professional ethics.

MISSION :

M1: Impart quality technical education in design and implementation of IT applications through innovative teaching - learning practice.

M2: Provide state-of-art computing infrastructure to enable practical learning experience that foster problem solving and technical communication skills.

M3: Provide quality learning experiences through experiential learning for students and faculty to carry out multidisciplinary research projects with innovative ideas and professional ethics for sustainable development.

PROGRAM EDUCATIONAL OBJECTIVES

PEO 1 : Demonstrate proficiency in fundamental concepts and advanced technologies of computer science in their careers and/or obtain a higher degree.

PEO 2 : Analyze complex computing problems in multidisciplinary area and creatively solve them with analytical decision making and programming skills

PEO 3 : Recognize ethical dilemma in work environment and apply professional code of Ethics to excel as successful software professional, researcher and entrepreneur.

PROGRAM SPECIFIC OUT COMES

PSO 1 : Apply the knowledge of programming languages, data structures, algorithms and standard software engineering principles to develop viable solutions for complex computing problems.

PSO 2 : Design and develop efficient Web and Mobile based applications under realistic constraints.

PSO3 : Apply theoretical principles of core and advanced computer science to solve engineering problems.

PROGRAM OUTCOMES

PO 1	Engineering Knowledge: Apply the knowledge of mathematics, science, engineering funda-
PO 2	Problem Analysis: Identify, formulate, review research literature, and analyze complex engineering problems reaching substantiated conclusions using first principles of mathematics, natural sciences, and engineering sciences.
PO 3	Design/Development of Solutions: Design solutions for complex engineering problems and design system components or processes that meet the specified needs with appropriate consideration for the public health and safety, and the cultural, societal, and environmental consider-
PO 4	Conduct Investigations of Complex Problems: Use research-based knowledge and research methods including design of experiments, analysis and interpretation of data, and synthesis of the information to provide valid conclusions.
PO 5	Modern Tool Usage: Create, select, and apply appropriate techniques, resources, and modern engineering and IT tools including prediction and modelling to complex engineering activities with an understanding of the limitations.
PO 6	The Engineer and Society: Apply reasoning informed by the contextual knowledge to assess societal, health, safety, legal and cultural issues and the consequent responsibilities relevant to the professional engineering practice.
PO 7	Environment and Sustainability: Understand the impact of the professional engineering solutions in societal and environmental contexts, and demonstrate the knowledge of, and need for sustainable development.
PO 8	Ethics: Apply ethical principles and commit to professional ethics and responsibilities and norms of the engineering practice.
PO 9	Individual and Team Work: Function effectively as an individual, and as a member or leader in diverse teams, and in multidisciplinary settings.
PO 10	Communication: Communicate effectively on complex engineering activities with the engineering community and with society at large, such as, being able to comprehend and write effective reports and design documentation, make effective presentations, and give and re-
PO 11	Project Management and Finance: Demonstrate knowledge and understanding of the engineering and management principles and apply these to one's own work, as a member and leader in a team, to manage projects and in multidisciplinary environments.
PO 12	Life-long Learning: Recognize the need for, and have the preparation and ability to engage in independent and life-long learning in the broadest context of technological change.

Chat GPT and its Capabilities

It's no mystery that ultra-modern language fashions like ChatGPT have long passed our wildest expectancies. It's surprising and even truly eerie to suppose that a language model possesses a broad expertise base and the potential to answer (nearly) any query convincingly.

Just a few hours after the release of this version, the hypothesis started approximately which fields of activity may be enriched or even changed by way of these models, which use instances can be carried out, and which of the various new begin-up thoughts arising from ChatGPT will prevail.

As choice-makers in an employer, it's crucial to apprehend how those advancements can be used to feature fees.

In this weblog publish, we can focus on the background in preference to the hype, offer examples of particular use cases in company conversation, and explain how implementing these AI structures may succeed.

There isn't any doubt that the continuous improvement of synthetic intelligence is gaining momentum. While ChatGPT is primarily based on a 3rd-technology version, a "GPT-4" is already on the horizon, and competing merchandise also are awaiting their vast second



What is ChatGPT?

What is ChatGPT



ChatGPT is an AI-powered conversational agent or chatbot developed by OpenAI. It is a large language model that uses deep learning algorithms to understand and generate human-like text responses to natural language inputs. ChatGPT is designed to simulate human conversation and provide relevant information, answer questions, offer suggestions, and carry out tasks in a conversational manner. It has been trained on a massive amount of text data and can generate responses that are contextually relevant and linguistically coherent.



Chat GPT and its Capabilities

In other words “ChatGPT is a massive language model trained to utilize OpenAI to apprehend and generate natural language. It uses deep getting-to-know and synthetic intelligence generation to conduct human-like customer conversations.”

ChatGPT is the modern representative from a class of AI systems that responds to human language (Texts). It is called “Natural Language Processing,” or NLP for quick. It is manufactured from an entire chain of innovations that began in 2017 with a new AI architecture.

In the subsequent years, the first AI fashions evolved primarily based on this structure that reached human-degree language understanding. In the ultimate years, the models learned to write and even have complete conversations with the consumer using ChatGPT.

ChatGPT stands out for generating credible and appropriate responses to user requests compared to other models. CharGPT can write programs, add comments to programs,

In addition to ChatGPT, there are many different language fashions in distinct forms: open source, proprietary, with dialog alternatives, or other abilities. It has become apparent that those abilities continued to develop with larger fashions and extra (specifically extraordinary) facts.



Unlike at the start predicted, there appears to be no higher limit. Conversely, the larger the models, the more abilities they gain!

These linguistic capabilities and the flexibility of ChatGPT are excellent, but using such large fashions is only sometimes precisely resource-friendly. Large models like ChatGPT are operated via external vendors who price every request to the model.

In addition, every request to large models now not simplest generates more expenses but consumes extra power and, for this reason, impacts the surroundings.

For instance, most chat requests from customers do not require comprehensive information about world history or the capability to provide amusing answers to every question. Instead, present chatbot offerings tailored to business statistics can deliver concise and correct solutions at a fraction of the fee.

ChatGPT

 Examples	 Capabilities	 Limitations
"Explain quantum computing in simple terms" →	Remembers what user said earlier in the conversation	May occasionally generate incorrect information
"Got any creative ideas for a 10 year old's birthday?" →	Allows user to provide follow-up corrections	May occasionally produce harmful instructions or biased content
"How do I make an HTTP request in Javascript?" →	Trained to decline inappropriate requests	Limited knowledge of world and events after 2021

What is ChatGPT|
➤

Submitted By :
Y SATISH KUMAR
202G1A05C0



The Technology behind Face Unlocking in Smartphones

What is Facial Recognition Technology?

Facial recognition technology is a part of biometric technology that identifies a person by face. It is also described as Biometric Artificial Intelligence, which is used to capture a person's facial texture and facial recognition such as eye retina, nose, and face shape. It is used for [facial recognition](#) in videos, photos, or real-time. Facial Recognition has been a great help for the security department to identify criminals based on the video footage.

Read developments about [5G wireless Technology](#) and what measures to take to [prevent cybercrime](#).

Which Face Unlocking Technology is used in Smartphones?

Android Basic Facial Technology: [Android operating system](#) introduced face unlocking from its “Ice Cream Sandwich” version (Android 4.0) in 2011. The main drawback of this face unlocking technique was that it used to store only 2D images so it was very easy for someone or a thief to fool the system and unlock the phone easily. As this technique was not fully efficient so users used this option along with a PIN or password. Surprisingly Google has discontinued the face unlock feature with the Android 10 release due to security reasons.

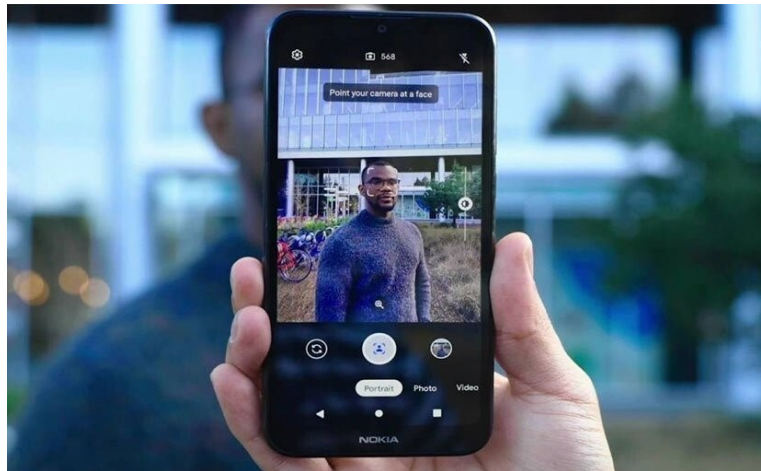

Samsung Iris Technology: Iris scanner in the Samsung device works based on the retina of eyes, just as human fingerprints are unique, the retina of the eye is also unique and no one can copy it. Samsung launched the Iris technology in its flagship devices Galaxy Tab Iris, Galaxy S7, and S7 Edge. Because earlier a normal front-facing camera could not scan the retina of the eye, Samsung gave a special infrared narrow-focus camera to its flagship smartphone so that it could easily scan the retina of the eye. One disadvantage of the Iris technology is that it generally requires close proximity to the camera, which can cause discomfort to the eyes for some.

Apple Face ID: Face ID is a type of facial recognition technology that the Apple company has designed and developed and started using in iPhone X, XS MAX, and iPad Pro (3rd & 4th Gen.) After introducing 3D facial recognition technology in 2017, Apple has continued using it in every new iPhones and iPads. With the face ID introduction, Apple decided to discontinue the other biometric authentication, touch ID from 2017 in iPhones and iPads.

The Technology behind Face Unlocking in Smartphones



Samsung Iris Technology

Here's how to set up Face ID:

1. Tap Settings
2. Tap Face ID & Passcode
3. Enter the Passcode (if prompted)
4. Tap Enroll Face (Under Face ID)
5. Tap 'Get Started' & follow the on-screen prompts
6. You will be asked to position your face within the frame
7. Move your head around so that it is scanned from all the angles

When setting up Face ID, you'll need to move your head around slowly so that Face ID can fully recognize your face. The setup process will take two scans of your face and then that's it.



Face ID. Image – Apple

Which Face Unlocking Technology is Better?

The Face unlocking biometric was introduced in 2016 with the Samsung Galaxy Note 7 whereas Apple first introduced Face ID in its iPhone X in 2017.

Apple Face ID technology is more promising with its accuracy and security and also it is based on a 3D facial recognition sensor. It is also capable of scanning the face even in the dark. This sensor consists of 3 parts, the first is the Dot Projector module, in which an infrared dot pattern is made on the face of the user, and the second module is the flood illuminator that is responsible to read the infrared patterns and generating a 3D facial map. The third module is an infrared camera that takes an infrared picture of these patterns. These patterns are encrypted and sent to a local Secure Enclave in the CPU of the device to match the registered face. If a user performs an unsuccessful scan 5 times, the Face ID becomes disabled for 48 hours. Also, Apple has claimed that 1 person out of 10,00,000 is likely to unlock the phone by another person with Face ID while 1 in 50,000 is likely to be in Touch ID. In addition, the Face ID system can easily recognize the face even when wearing makeup, hats, scarves, and glasses, and also it can adapt to the age factor of a person.

Submitted By :
DODDI NARESH
202G1A0516



Virtual Reality

What's Virtual Reality?

The definition of digital reality comes, logically, from the definitions for both 'digital' and 'reality'. Real situations or real events are reproduced using digital methods which are a part of some software applications. So the definition of 'digital reality' essentially means 'close-to-reality'. This could, obviously, describes a particular type of real emulation. Virtual reality is all about reproducing real situations or events using digital methods which are a part of some software application.

We know the world by our senses and perception systems. In school, most of us learned that we have five senses: taste, contact, scent, sight, and hearing. They may be solely our most apparent sense organs. The simple fact is that people have a lot more senses than this, like a sense of balance for example. These different sensory inputs, plus some extraordinary processing of sensory info by our brains ensure that individuals have a wealthy flow of data from the environment to the minds.

Everything that we know about our reality comes from our senses. In other words, our fundamental knowledge of reality is simply a mix of sensory info and brain sense-creating systems for that content. It stands to reason then, that if you can update your senses with made-up information; your belief of reality would also change in reaction to it. You would be given a model of reality that isn't in reality there, however, from your very perspective, it may be perceived as real.

How is virtual reality achieved?

At present, virtual reality is usually implemented utilizing computer technology. You would discover a range of systems that are used for this precise intention, such as for example headsets, Omni-directional treadmills, and extraordinary gloves. These are accustomed to stimulating our senses collectively to create the phantasm of reality. This is a new stream, which is growing in the market. Lots of companies are making, inroads in this. People are spending a huge amount on research and development.

That's more challenging than it sounds since our senses and brains are evolved to grant us a finely synchronized and mediated experience. If whatever is even only a little off, we could normally tell. This is where you may hear terms such as realism. Digital reality technology know-how ought to take our physiology into consideration. For example, the human visual subject doesn't seem like a video frame. We've one hundred eighty quantities of imaginative and prescient and though you're not always consciously aware of your peripheral vision if it were gone you'd notice. Equally when what your eyes and the vestibular system in your ears inform you are available in the clash, it might trigger motion illness.



How does Virtual Reality work?

The basis of a good VR experience comes with the headset.

The VR headset is a head-mounted display that blocks the outside world as well as displays a 3D world and stitched images in order to create the simulation for the user. In some cases, the screen will be set to focus and fill our peripheral vision or to block out outside the world. While you put on the professional series headset, you must feel as if you are in a scene & interacting with that.

Examples

VR technology improves with immersion also. New headsets, like Samsung Gear VR, and Oculus Rift, system are all available for use at anyone's home. Oculus Rift is been heralded as the premier system and Samsung Gear works with the latest Samsung Galaxy phones to turn smartphone screens into VR experiences.

Virtual Reality

Features of the VR systems include:

- **Immersion:** The goal of the VR system is to immerse the user in a new simulation environment. It means filling the peripheral vision by using the visor and introducing the sound canceling all surrounding sound headphones that will put them in a scene and give control over the scene with the head movements.
- **Interaction:** In a lot of games and films, app creators work in creating immersive experiences. Using a specialty controller in the new PlayStation, for example, will help the users to interact with scenes & control elements. The ability to pick objects in a scene and interact with the characters will improve immersion further and add to the VR simulation's value.

Some of the value-for-money VR headsets available for your smartphone are:

1. IncrediSonic VR Glasses with Bluetooth Remote Gaming Controller: This device is available on [amazon.com](https://www.amazon.com) for people from the United States. Turn your smartphone into the ultimate 3D machine for 3D games and split screen movies; works with over 300+ iOS/Android VR apps on Apple App Store and Google Play Store. A truly fun and immersive experience for any age. Bluetooth remote has many applications: control VR video games, use as a selfie shutter controller, compatible with Windows and Macs with Bluetooth, remote control for cellphones, fast forward, rewind, pause and play movies.

2. 3Dream VR headset:

This device is available on [amazon](https://www.amazon.com) for people from India. Comfortable headband, super face foam protector, the ideal heat dissipating design ventilation holes are convenient for inserting earphones and charging. Within a second change your phone into Imax cinema and enjoy the 3D world anywhere and anytime. 3dream has two side vents for charging and earphone connection with your phone. New redesigned 42 mm lenses let you enjoy the best virtual reality experience with best -in-class clarity and zero glass door effect. 3dream works with most mobiles with a gyroscope, and accelerometer for head tracking, 3dream is iPhone and Android compatible.

3. Samsung Gear VR – Virtual Reality Headset (US Version): Lightweight, so you can play and watch more comfortably. Wide field of view, precise head-tracking, and low latency bring reality to the virtual. Be transported to amazing new worlds in games, videos, and images. Thousands of 360-degree panoramic photos.

Improved fit, including room for most eyeglasses and improved padding for extra comfort and durability. Lightweight, so you can play and watch more comfortably. Easy to use the touchpad. Compatible with: Samsung Galaxy Note5, S6 edge+, S6, S6 edge.

4. Irusu Play VR Plus: This device is available on [amazon](https://www.amazon.com) for people from India. Experience 360 videos, 3d, and VR games like never before. Lenses made using vacuum ion plating refining, are capable of blocking electromagnetic radiation and have no side effects on vision. Use HD optical resin lenses, 8-layer nano-coating, and 5 times polishing. Reducing deformity and glare, effectively preventing visual fatigue, restoring 3d reality under broad vision, and reproducing a lossless virtual reality world.

Free Bluetooth remote and magnetic clicker: most VR apps require on-screen selection/triggering actions which can be easily accomplished through a magnetic clicker or free remote. It is a money saver as buyers don't need to buy an extra 600 bucks remote to just trigger/select actions on VR apps (the remote does not work properly with the latest ios 10.2 version). The mobiles should have a gyroscope and accelerometer for head tracking. Hence if mobiles have these two sensors they can start using this VR headset. The free magnetic clicker works with a mobile magnetometer. Works with leading mobile brands like Apple iPhone 6 and plus, Samsung, Xiaomi, Lenovo, Oneplus, Moto, LG, Nexus, Google Pixel, and other mobiles with a gyroscope.

Submitted By :

C RADHA GOWTHAMI

202G1A0513



Semantic Web

The web today enables people to access documents and services on the Internet but today's methods require human intelligence. The semantic web augments the current web with formalized knowledge and well-formatted data that can be processed by computers. The semantic web is a vision of information that is understandable by computers, so that they can perform more of the tedious work involved in finding, combining, and acting upon information on the web. Data that is generally hidden away in HTML files is often useful in some contexts, but there is no global system for publishing data in such a way that it can be easily processed by anyone. This makes Semantic Web a rational solution for the problem. This will enable computers to assist human users in tasks and understand data the way they cannot today. If you want to understand how the world of internet works,. The layered architecture serves as the basic building block of the system and supports the vision of a Web imbued with meaning. The similarities that it shares with the object-oriented programming language has made the Unified Modelling Language usable by both object-oriented Programming and semantic web development and the Semantic Web Browsers, extend the notion of the Web browser into the Semantic Web. There will also be the creation of new applications and services from combinations of existing service.

Introduction

Resource Description Framework (RDF), a variety of data interchange formats (e.g. RDF/XML, N3, Turtle, N-Triples), and notations such as RDF Schema (RDFS) and the Web Ontology Language (OWL), all of which are intended to provide a formal description of concepts, terms, and relationships within a given knowledge domain. Semantics is the study of meaning. It is the branch of linguistics and logic concerned with meaning. It's as old as the ancient Greeks. For most of us it was a deadly dull sub-discipline of philosophy, to be avoided. But it turns out that we can't avoid it. We are drowning in a sea of data which occasionally is generously referred to as information, but the truth is that almost all of it must be interpreted by humans to be of any use. The growth and availability of data and, therefore, our need to consider it in decision-making and planning is growing exponentially, and our systems, rather than helping with this, are for the most part contributing to the problem.

The Semantic Web is a web that is able to describe things in a way that computers can understand. The Semantic Web is not about links between web pages. The Semantic Web describes the relationships between things (like A is a part of B and Y is a member of Z) and the properties of things (like size, weight, age, and price). In an evolving development of the World Wide Web in which the meaning (semantics) of information and services on the web is defined, making it possible for the web to "understand" and satisfy the requests of people and machines to use the web content. It derives from World Wide Web Consortium director Sir [Tim Berners-Lee](#)'s vision of the Web as a universal medium for data, information, and knowledge exchange. Tim is also known for introducing HTTP communications, WWW, [URIs](#).

Implementing the Semantic Web requires adding semantic metadata, or data that describes data, to information resources. This will allow machines to effectively process the data based on the semantic information that describes it. When there is enough semantic information associated with data, computers can make inferences about the data, i.e., understand what a data resource is and how it relates to other data. At its core, the semantic web comprises a set of design principles, collaborative working groups, and a variety of enabling technologies. Some elements of the semantic web are expressed as prospective future possibilities that are yet to be implemented. Other elements of the semantic web are expressed in formal specifications. Some of these include Resource Description Framework (RDF), a variety of data interchange formats (e.g. RDF/XML, N3, Turtle, N-Triples), and notations such as RDF Schema (RDFS) and the Web Ontology Language (OWL), all of which are intended to provide a formal description of concepts, terms, and relationships within a given knowledge domain.

Semantic Web

Architecture

The common use of the term Semantic Web is to identify a set of technologies, tools, and standards which form the basic building blocks of a system that could support the vision of a Web imbued with meaning. The Semantic Web has been developing a layered architecture, which is often represented using a diagram first proposed by Tim Berners-Lee, with many variations since.

While necessarily a simplification which has to be used with some caution, it nevertheless gives a reasonable conceptualization of the various components of the semantic Web. We describe briefly these layers.

A. Unicode and URI:

Unicode, the Standard for computer character representation, and URIs, the standard for identifying and locating resources (such as pages on the Web), provide a baseline for representing characters used in most of the languages in the world, and for identifying resources.

B. XML:

XML and its related Standards, such as Namespaces, and Schemas, form a common means for structuring data on the Web but without communicating the meaning of the data. These are well established within the Web already.

C. Resource Description Framework:

RDF is the first layer of the Semantic Web proper. RDF is a simple metadata representation framework, using URIs to identify Web-based resources and a graph model for describing relationships between resources. Several syntactic representations are available, including a standard XML format. RDF Schema: a simple type modeling language for describing classes of resources and properties between them in the basic RDF model. It provides a simple reasoning framework for inferring types of resources.

D. Ontologies:

a richer language for providing more complex constraints on the types of resources and their properties.

E. Logic and Proof:

an (automatic) reasoning system provided on top of the ontology structure to make new inferences. Thus, using such a system, a software agent can make deductions as to whether a particular resource satisfies its requirements (and vice versa).

F. Trust:

The final layer of the stack addresses issues of trust that the Semantic Web can support. This component has not progressed far beyond a vision of allowing people to ask questions of the trustworthiness of the information on the Web, in order to provide an assurance of its quality.

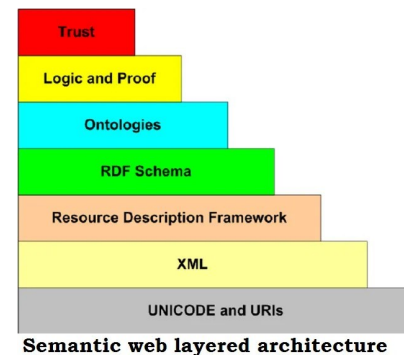

Submitted By :

B ANITHA

202G1A0568



Software-Defined Radio

Software-defined radio (SDR) is a technology that enables communication systems to be implemented in software, rather than through specialized hardware. This allows for greater flexibility, improved performance, and reduced costs compared to traditional radio communication systems.

Certain characteristics of Software-defined radios make them unique from other types of radios. At its core, SDR involves the use of software to control radio frequency (RF) hardware, such as transceivers, amplifiers, and antennas. By controlling these hardware components through software, SDR systems can adapt to changing environments and operate across a wide range of frequencies and modulation schemes.

As the name implies, an SDR is a radio that has the ability to be transformed through the use of software or re-definable logic. One of the primary benefits of SDR is its flexibility. Traditional radio communication systems are typically implemented using fixed hardware that is designed to operate at specific frequencies and with specific modulation schemes. This makes it difficult to adapt to changing requirements or to support multiple communication protocols.

In contrast, SDR systems can be reconfigured in software to support different frequencies and modulation schemes. This means that a single SDR system can be used to implement multiple communication protocols or to adapt to changing requirements in real time.

Significant amounts of signal processing are handed over to the general-purpose processor, rather than to special-purpose hardware. Such a design produces a radio which can receive and transmit widely different radio protocols (also called waveforms) based on the underlying software used.

What does the SDR hardware consist of?

- Radio Frequency Unit
- Analog to Digital/Digital to Analog Converter
- Baseband Unit
- An audio amp/filter
- A sound card

A PC with some clever Digital Signal Processing software

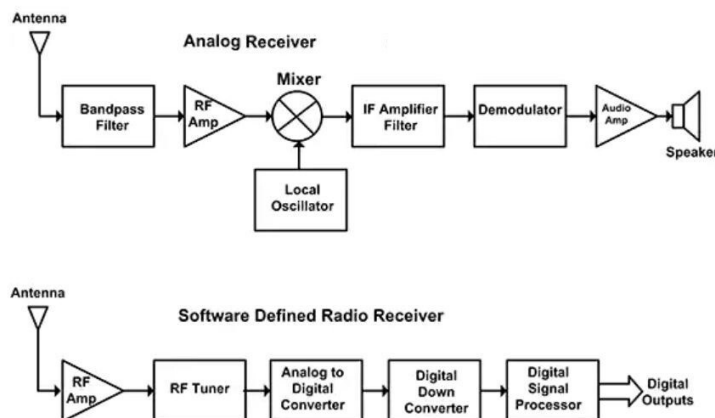

GNU Radio is an open-source software development toolkit and it provides signal processing blocks to implement software radios for free. Those who are interested in building their own SDR can reach out [GNU Radio](#).

Software-Defined Radio

Applications of Software-Defined Radio

SDR has a wide range of applications in various industries, including:

- **Military communications:** SDR can provide secure and flexible communication systems for military operations, allowing soldiers to communicate over different frequencies and formats with ease.
- **Public safety:** SDR can be used by emergency responders, such as police, firefighters, and paramedics, to communicate during disasters or emergencies. SDR can enable interoperability between different agencies, making it easier to coordinate responses.
- **Broadcasting:** SDR is useful in broadcasting to improve the quality of transmissions and allow for the delivery of multiple services over a single frequency band.
- **Wireless communication:** SDR can be used in wireless communication systems, such as Wi-Fi and cellular networks, to provide more efficient and flexible communication services.
- **Amateur radio:** SDR has revolutionized amateur radio by making it easier to receive and decode signals from around the world.
- **Satellite communication:** SDR can be used in satellite communication to improve the flexibility of the communication system and provide better coverage.
- **Internet of Things (IoT):** SDR can be used in IoT applications to enable communication between devices and improve the efficiency of the network.

Radar: SDR can be used in radar systems, such as weather radar, to improve the resolution and accuracy of the system.

Advantages of Software-Defined Radio

One of the key advantages of SDR is its flexibility. Traditional radio communication systems are designed for specific applications and are not easily reconfigured for other uses. SDR, on the other hand, can be easily reconfigured to support different types of radio communication, such as AM, FM, and digital modes.

SDR has the ability to process multiple signals simultaneously. With traditional radio systems, multiple signals would require multiple hardware components. With SDR, multiple signals can be processed in software, reducing the need for hardware and making the system more cost-effective.

SDR also allows for greater control and monitoring of radio communication systems. With traditional radio systems, it can be difficult to monitor and analyze the signals being transmitted and received. With SDR, the signals can be easily monitored and analyzed in real time, allowing for better control and optimization of the system.

SDRs offer a cheaper radio frequency front-end design, unlike the complex classic RF design. With the design of a reliable SDR, the quality and performance of the SDR can be enhanced by the digital hardware to reduce the cost and complexity of the RF front end. Digital hardware devices would include Digital Signal Processor (DSP), Field Programmable Gate-Array (FPGA), and General Purpose Processor (GPP)

Submitted By :

B DIVYA SREE

212G1A0505



Brain controlled car for disabled using Artificial Intelligence

This article explains a brain-driven and brain-controlled car for the disabled, which would be of great help to physically disabled people. Since these cars will rely only on what the individual is thinking they will hence not require any physical movement on the part of the individual. The car integrates signals from a variety of sensors like video, weather monitor, anti-collision, etc. It also has an automatic navigation system in case of emergency. The car works on the asynchronous mechanism of [artificial intelligence](#).

In the 40s and 50s, a number of researchers explored the connection between neurology, information theory, and cybernetics. Some of them built machines that used electronic networks to exhibit rudimentary intelligence, such as W. Grey Walter's turtles and the Johns Hopkins Beast. Many of these researchers gathered for meetings of the Teleological Society at Princeton and the Ratio Club in England. Most researchers hope that their work will eventually be incorporated into a machine with general intelligence (known as AI), combining all the skills above and exceeding human abilities at most or all of them. A few believe that anthropomorphic features like artificial consciousness or an artificial brain may be required for such a project.

Introduction

A [brain computer interface](#) (BCI), sometimes called a direct neural interface or a brain-machine interface – is a direct communication pathway between a human or animal brain (or brain cell culture) and an external device. In one-way BCIs, computers either accept commands from the brain or send signals to it (for example, to restore vision) but not both. Two-way BCIs would allow brains and external devices to exchange information in both directions but have yet to be successfully implanted in animals or humans.



In this definition, the word brain means the brain or nervous system of an organic life form rather than the mind. Computer means any processing or computational device, from simple circuits to silicon chips (including hypothetical future technologies such as quantum computing).

Once the driver (disabled) nears the car. The security system of the car is activated. Images, as well as thermographic results of the driver, are previously fed into the database of the computer. If the video images match the database entries then the security system advances to the next stage. Here the thermographic image verification is done with the database. Once the driver passes this stage the door slides to the sides and a ramp is lowered from its floor. The ramp has flip actuators in its lower end.

Once the driver enters the ramp, the flip actuates the ramp to be lifted horizontally. Then robotic arms assist the driver to his seat. As soon as the driver is seated the EEG (electroencephalogram) helmet, attached to the top of the seat, is lowered and suitably placed on the driver's head. A wide screen of the computer is placed at an angle aesthetically suitable to the driver. Each program can be controlled either directly by a mouse or by a shortcut. For starting the car, the start button is clicked. Accordingly, the computer switches ON the circuit from the battery to the A.C. Series Induction motors.

Bio-control System

The biocontrol system integrates signals from various other systems and compares them with originals in the database. It comprises the following systems:

- Brain-computer interface
- Automatic security system
- Automatic navigation system

Now let us discuss each system in detail.

Brain controlled car for disabled using Artificial Intelligence

Brain-computer Interface

Brain-computer interfaces will increase acceptance by offering customized, intelligent help and training, especially for the non-expert user. The development of such a flexible interface paradigm raises several challenges in the areas of machine perception and automatic explanation. The teams doing research in this field have developed a single-position, brain-controlled switch that responds to specific patterns detected in spatiotemporal electroencephalograms (EEG) measured from the human scalp. We refer to this initial design as the Low-Frequency.

Asynchronous Switch Design (LF-ASD)

The EEG is then filtered and run through a fast Fourier transform before being displayed as a three-dimensional graphic. The data can then be piped into MIDI compatible music programs. Furthermore, MIDI can be adjusted to control other external processes, such as robotics. The experimental control system is configured for the particular task being used in the evaluation. Real Time Workshop generates all the control programs from Simulink models and C/C++ using MS Visual C++ 6.0. Analysis of data is mostly done within Matlab environment.

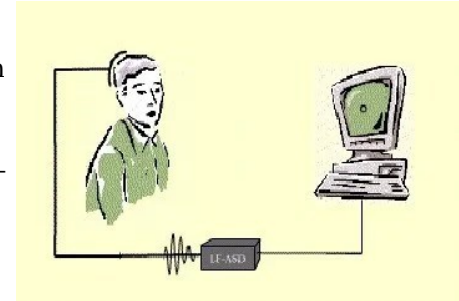

Features of EEG band

- Remote analysis data can be sent and analyzed in real-time over a network or modem connection.
- Data can be fully exported in raw data, FFT & average formats.
- Ultra low noise balanced DC coupling amplifier.
- Max input 100microV p-p, minimum digital resolution is $100 \text{ microV p-p} / 256 = 0.390625 \text{ micro V p-p}$. FFT point can select from 128 (0.9375 Hz), 256 (0.46875 Hz), 512(0.234375 Hz resolution).
- Support for additional serial ports via plug-in board; allows extensive serial input & output control.
- Infinite real-time data acquisition (dependent upon hard drive size).
- Real-time 3-D & 2-D FFT with peak indicator, Raw Data, and Horizontal Bar displays with Quick Draw mode.
- Full 24 bit color support; data can be analyzed with any standard or user.
- Customized color palettes; color cycling available in 8 bit mode with QuickDrawmode.
- Interactive real-time FFT filtering with Quick Draw mode. Real-time 3-D FFT (left, right, coherence and relative coherence), raw wave, sphere frequency and six brain wave switch in one OpenGL display.

Full Brainwave driven Quick Time Movie, Quick Time MIDI control; user configurable Full Brain wave driven sound control, support for 16 bit sound; user configurable Full image capture and playback control; user configurable.



Brain controlled car for disabled using Artificial Intelligence

Test Results Comparing Driver Accuracy With/Without BCI

1. Able-bodied subjects using imaginary movements could attain equal or better control accuracies than able-bodied subjects using real movements.
2. Subjects demonstrated activation accuracies in the range of 70-82% with false activations below 2%.
3. Accuracies using actual finger movements were observed in the range 36-83%.
4. The average classification accuracy of imaginary movements was over 99%.

The principle behind the whole mechanism is that the impulse of the human brain can be tracked and even decoded. The Low-Frequency Asynchronous Switch Design traces the motor neurons in the brain. When the driver attempts a physical movement, he/she sends an impulse to the motor neuron. These motor neurons carry the signal to the physical components such as hands or legs. Hence we decode the message at the motor neuron to obtain maximum accuracy. By observing the sensory neurons we can monitor the eye movement of the driver.

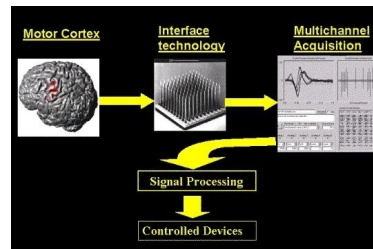

Brain-to-Machine Mechanism

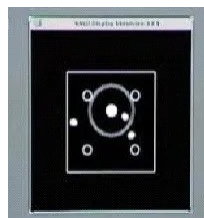

Fig. Eyeball Tracking

As the eye moves, the cursor on the screen also moves and is also brightened when the driver concentrates on one particular point in his environment. The sensors, which are placed at the front and rear ends of the car, send a live feedback of the environment to the computer. The steering wheel is turned through a specific angle by electromechanical actuators. The angle of turn is calibrated from the distance moved by the dot on the screen.

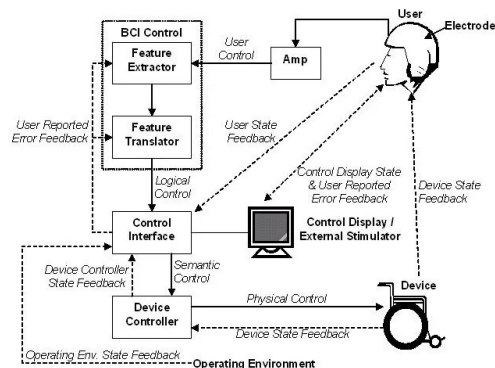
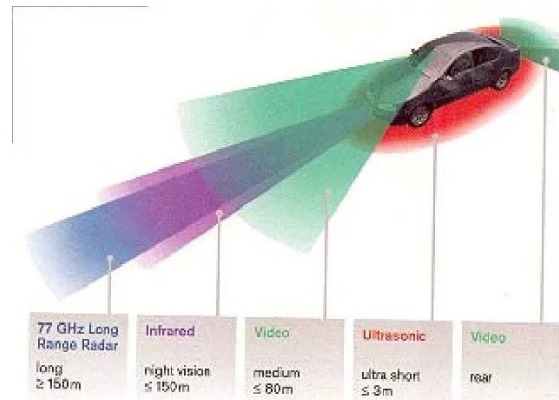

Fig. Electromechanical Control Unit

Brain controlled car for disabled using Artificial Intelligence



Automatic Security System

The EEG of the driver is monitored continually. When it drops less than 4 Hz then the driver is in an unstable state. A message is given to the driver for confirmation and waits for some time, to continue the drive. A confirmed reply activates the program for an automatic drive. If the driver doesn't give reply then the computer prompts the driver for the destination before the drive.

Automatic Navigation System

As the computer is based on artificial intelligence it automatically monitors every route the car travels and stores it in its map database for future use. The map database is analyzed and the shortest route to the destination is chosen. With traffic monitoring system provided by XM satellite radio the computer drives the car automatically. Video and anti-collision sensors mainly assist this drive by providing a continuous live feed of the environment up to 180 m, which is sufficient for the purpose.

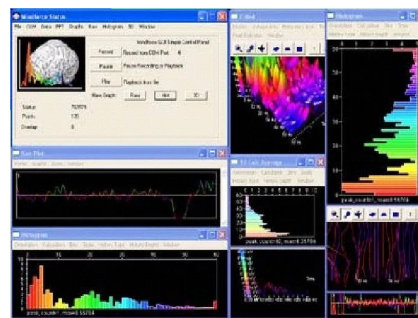

Fig. EEG Analysis Window

Submitted By :
 C THIRSHA SAI
 212G1A0511



The Role of Artificial Intelligence in Healthcare Industry

The healthcare business is widely recognized as one of the most important and difficult to operate on the whole wide planet. It is a sector that has a considerable influence on society as a whole and is constantly undergoing a change in response to the requirements posed by patients. In this article, we will discuss the Role of Artificial Intelligence in healthcare industry.

Artificial intelligence (AI) and machine learning are quickly becoming one of the most game-changing technologies in the healthcare sector. Read more about [Artificial Intelligence](#).



There are a wide variety of applications that may be developed using Artificial Intelligence in healthcare sector, and these applications have the potential to significantly disrupt the business. In this article, we will discuss some of the ways that AI is changing the landscape of the healthcare sector.

Disease detection and diagnosis

The improvement in illness identification and diagnosis is one of the most important ways that AI is having an influence on the healthcare industry.

X-rays, CT scans, and MRIs are just some of the medical pictures that may be analyzed more precisely and rapidly with the use of artificial intelligence (AI). [Artificial intelligence Software](#) is able to spot irregularities that human observers would overlook, which can lead to earlier discovery and more successful treatment.

AI may also be used to examine patients' medical histories and recognize trends, which can lead to a more accurate diagnosis of illnesses.

For instance, AI may be used to do retinal image analysis in order to identify early warning signals of diabetic retinopathy, a disease that, if left untreated, can lead to blindness in diabetic patients.

[Artificial Intelligence](#) algorithms are able to identify changes in the retina that the human eye may not be able to see since they analyze photographs of the retina. Because of this, medical professionals may be able to recognize the problem sooner, which may lead to more successful treatment and better results.

Another illustration of this would be the use of AI to screen for breast cancer. Artificial intelligence algorithms are capable of analyzing mammograms and locating possible malignancies with a higher degree of accuracy than human observers.

This may assist medical professionals in detecting breast cancer at an earlier stage, which can lead to more successful treatment and better results.

Personalized treatment plans

Also, AI is assisting in the development of individualized treatment programs for individuals. AI systems are able to recognize patterns in large volumes of medical data and make educated guesses about how a patient will react to a certain therapy by using this knowledge.

This information may assist medical professionals in the development of individualized treatment programs that are more likely to be successful and include a lower risk of adverse effects. You can also integrate

The Role of Artificial Intelligence in Healthcare Industry

Remote patient monitoring

AI is also being used to remotely monitor individuals in order to identify possible health concerns before they become more severe. Artificial intelligence algorithms may monitor a patient's vital signs and warn healthcare personnel if there are any alarming changes.

This monitoring can take place with the use of wearable gadgets. Because of this, medical professionals may be able to act earlier and so avoid more significant consequences.

For instance, AI may be used in the monitoring of individuals who suffer from cardiovascular disease. Artificial intelligence systems may identify changes in a patient's heart rate by evaluating data from wearable devices.

These algorithms can then inform medical professionals if the detected changes are alarming. Because of this, medical professionals may be able to act earlier and so avoid more catastrophic consequences, such as heart attacks.

Drug discovery and development

AI is also playing an essential part in the process of discovering and developing new drugs. AI systems can find possible therapeutic targets and anticipate how particular substances will interact with the human body by evaluating massive volumes of data.

This is accomplished via the use of data mining. The process of developing new drugs might be sped up and made more effective with the aid of this.

For instance, artificial intelligence may be used to evaluate genetic data and locate possible medication targets.

AI algorithms may assist researchers in developing pharmaceuticals that target the genetic abnormalities that cause particular illnesses. This will ultimately lead to more effective therapies being designed.

AI may also be used to make predictions about the effects that medications will have on the human body. AI algorithms may make accurate predictions about the effects that medications would have on diverse populations by examining data from clinical trials.

One example of this would be patients who have particular genetic mutations. This may assist the physician in selecting the appropriate therapy for the patient, resulting in.

Submitted By :

K MOULA BEE

212G1A0590



Face Identification and Recognition

Face identification and recognition technology is very well known for identifying a person from a video clip or image. This is done using many ways like comparing facial features, using a neural network, or using [eigenfaces](#).

What Is Facial Recognition Technology?

Facial recognition involves the use of algorithms to scan and match the contours of a person's face. The algorithms are either feature-based or image-based. The programming is so advanced it can identify the subtlest of differences. Facial recognition tools are designed to determine matrices like jaw length, the width of the nose, eye socket depth, and chin shape. The details are then compared with representations already collected in a database.

A face authentication system based on principal component analysis and neural networks consists of three stages; **pre-processing**, **principal component analysis**, and **recognition**.

- In the pre-processing stage, normalization illumination, and head orientation are done..
- The principal component analysis is applied to find the aspects of the face which are important for identification. [Eigenvectors](#) and eigenfaces are calculated from the initial face image set. New faces are projected onto the space expanded by eigenfaces and represented by a weighted sum of the eigenfaces. These weights are used to identify the faces.
- In the third step, a Neural network is used to create the face database. Recognition and authentication of the face are done by using the weights generated by eigenfaces.

Eigenfaces is the name given to a set of eigenvectors. Eigenface provides an easy way for face recognition as its training process is completely automatic and easy to code. Eigenface adequately reduces statistical complexity in face image representation. Eigenfaces can handle large databases and once the eigenfaces of a database are calculated, face recognition can be achieved in real-time.

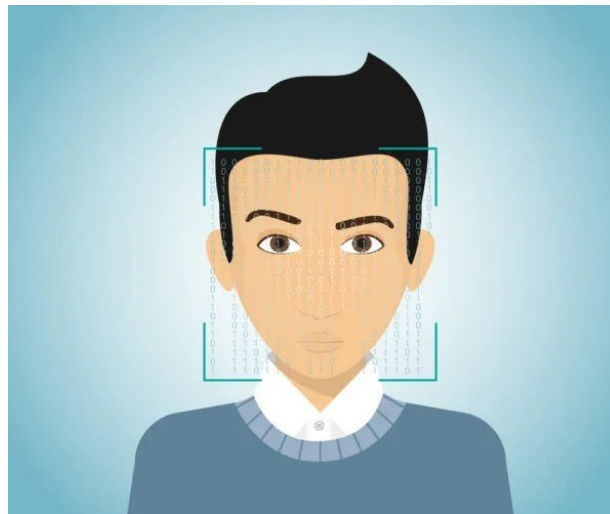

Face Identification and Recognition

Some of the well-known software with face recognition ability include:

- [iPhoto](#) (Apple)
- [Lightroom](#) (Adobe)
- [OpenCV](#) (Open Source)
- [Photos](#) (Apple)
- [Photoshop Elements](#) (Adobe Systems)
- [Picasa](#) (Google)
- [Picture Motion Browser](#) (Sony)
- [Windows Live Photo Gallery](#) (Microsoft)
- [FotoBounce](#) (Applied Recognition Inc)
- [DeepFace](#) (Facebook)

Benefits of Facial Recognition Technology

Facial recognition has evolved from its nascent stage. It has improved to show extremely accurate results. Recent improvements in technology have enabled a broader implementation of facial recognition. More and more companies are benefitting from facial recognition tools.

Facial recognition has many applications in a variety of fields such as security systems, videoconferencing and identification however face detection is not 100% accurate most of the time. We will talk about the drawbacks of Face identification and Recognition later in this post.

1. Ensure Better Security

The world has progressed from security measures like multi-factor authentication and security questions. Technological advancements have paved the way for companies to incorporate latest security measures. Examples include fingerprint, eye and face scanners. Facial recognition tools are the new face of security. It offers great protection against cyber-attacks and information theft. Each employee has a unique face-print that is stored in a database. Advanced algorithms run scans on the face and convert the result into mathematical language. The details are then compared with the information stored in the existing database.

2. Improve Employee Productivity

Smartphones are a great distraction and people spend hours on these “mini-computers”. But using smartphones during work can affect productivity. In fact, [according to the World Economic Forum](#), about 36% of workers belonging to the millennial group as well as Gen X spend “two hours or more checking their smartphones for personal activities during the workday.”

Using facial recognition can help address the said concern. Companies that use facial recognition tools are more likely to improve employee productivity. They are able to monitor the check-in and check-out time of employees in addition to curbing unauthorized breaks. Face recognition programs and software allow businesses to record time and flag employees who fail to deliver tasks on time.

Face Identification and Recognition

3. Ensure Data Privacy

The importance of data privacy cannot be overstated in this digital age. Almost all business operations have gone digital. Records of companies and employees are stored in large databases. Facial recognition prevents unauthorized access to employee data. It also allows businesses to protect the different levels of clearance when it comes to HR and accounting records.

Line managers can use facial recognition to access the time sheets of their subordinates. Individual employees, however, have to be provided with limited access to company information. They can use facial recognition tools to access job-specific information.

4. Ensure Time Management

There was a time when attendance records were limited to registers and other safe-keeping books. Habitual latecomers would ask their colleagues to fill in their attendance. Errors were a routine thing due to mismanagement and lack of proper time-tracking techniques.

The advent of tools such as facial recognition and thumb impression changed the game. With facial recognition, chances of human error and inaccuracies are minimized. Furthermore, employees are no longer able to falsify their entry and exit times due to time-tracking programs.

5. Access Information with Greater Ease

Facial recognition is a convenient way to access information. It does not require any code or special key for verification. You don't have to worry about the loss of external information because it doesn't involve one. Get your face scanned and access your locker. It's that simple.

6. Improve Customer Experience

Facial recognition is evolving to enable companies to pursue target advertising techniques with greater clarity. It is expected that facial recognition will be in the mainstream hotel market by 2025. Many hotel chains are already experimenting with targeted dining recommendations using facial recognition tools.

Drawbacks with Face Detection and Recognition:

Face detection and recognition have failed many times because of various reasons like changes in expressions, plastic surgery, the angle at which a picture is taken, etc. Also, as the person grows old the saved data has no value.

When Face recognition was used to prevent public crimes, it failed completely as people were using masks to cover their faces.

Submitted By :
R G RANGE GOWD
212G5A0512





Anantha Lakshmi
Institute of Technology & Sciences

Address :
Near SK University,
Itukulapalli V),
Anantapur Dist. A.P. India-515721

Phone : 8328579395
8801110569

Email Id : csehod@alits.ac.in

ABOUT THE DEPARTMENT

Computer Science and Engineering is at the core of the information age. To prepare our students for the tremendous opportunities in the field, the CSE Department is strongly committed to excellence in both education and research. Our majors are designed to provide a strong foundation in the core areas of Computer Science and Engineering.

Our majors are designed to provide a strong foundation in the core areas of Computer Science and Engineering. Our vibrant graduate programs prepare students for positions in industry and academia. Since its inception, the department has always been recognized for excellence in teaching. The Department provides an outstanding teaching environment complemented by superior teaching for its students to flourish in. Graduates from the department are recruited by both academia and industry.

The Department of Computer Science and Engineering with its cohesive team of faculty members offers a sound program at the UG as well as the PG levels. The curriculum is a blend of the conventional and the radical. It is updated regularly to keep up with the growing demands and the changing trends of the software industry and research laboratories.



College Code : ALTS

